

HUMAN KNEE PROSTHESIS EQUIPPED WITH FORCE SENSORS

M. Gazzoli, E. Sardini, M. Serpelloni

Department of Information Engineering, University of Brescia, Brescia, Italy
{marco.gazzoli, emilio.sardini, mauro.serpelloni}@ing.unibs.it

G. Donzella

Department of Mechanical Engineering, University of Brescia, Brescia, Italy
giorgio.donzella@ing.unibs.it

Keywords: Measurement in human knee, Instrumented implant, Biomechanics, Force transducer, Strain sensor.

Abstract: In-vivo monitoring of human knee implants after total arthroplasty increases the knowledge about articular motion and loading conditions. The proposed knee prosthesis equipped with force sensors executes force measurements in polyethylene human knee prosthesis by two sensorized metal bars positioned under the femoral condyles and fully contained in the polyethylene insert. In this paper, a new force sensor, which acts in the knee integrated in the prosthesis, is proposed with the aim of reducing the hysteresis of polyethylene material and increase the rigidity of the insert. The fabricated sensors are characterized and tested by means of a mechanical press controlled load. The realized conditioning electronics is done by low power components and it can be integrated in an autonomous system. The forces transmitted across the knee joint during normal human activities such as walking, running or climbing can be directly measured. Furthermore, the device can be used to improve design, refine surgical instrumentation, guide post-operative physical therapy and detect human activities that can overload the system.

1 INTRODUCTION

The measurement of forces acting on knees, while walking or during normal movements of the leg is a topic widely discussed in (Gattiker, Umbrecht, Neuenschwander, Sennhauser, Hierold, 2008), (Westerhoff, Graichen, Bender, Rohlmann, Bergmann, 2009), (Heinlein, Graichen, Bender, Rohlmann, Bergmann, 2007). In Heinlein et al. (2007), a measurement system detects the forces using strain gauge sensors: the authors propose the measurement of six degrees of freedom of the knee (three forces and three moments) using a titanium frame inserted in the tibia with six strain gauges. In (Crescini, Sardini, Serpelloni, 2009), an instrumented knee prosthesis is proposed for measure the forces between the femur and tibia by magnetoresistors. These sensors measure the deformation of the polyethylene surface of the prosthesis in contact with the condyles of the tibia. But, in this configuration and particular design, the material shows hysteresis after application of forces,

because the polyethylene material has a viscoelastic component. The proposed system relies on the use of a new sensors technology. A typical prosthesis for human knee is composed by three principal inserts. In Figure 1, the 3D model of the adopted prosthesis is represented. The femoral and tibial insert are made on titanium and the tibial plate is made of polyethylene. On the top of the implant two excavations are carried out (Figure 1) centered under the contact point between the condyles and the polyethylene insert. These holes are made for accommodate two sensorized metal bars. Two strain gauges are placed under the metal bars for measuring the deformations and correlate the measured data to the force applied. In this way, the sensors are closer to the focal point of the condyles with the prosthesis, and this placing allows integrating electronics and sensors in the polyethylene insert. The realized sensors and conditioning electronics is done by low power components and it can be integrated in an autonomous system as proposed in (Crescini et al., 2009).

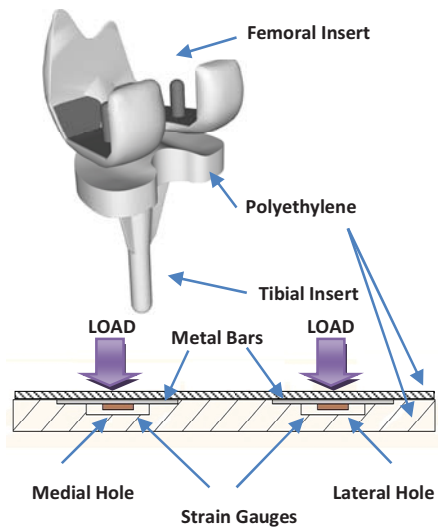

Figure 1: Section of upper polyethylene insert with integrated force sensors.

2 SENSOR

With the aim of reducing the hysteresis of polyethylene material, in this paper, a new force sensor that acts in the knee integrated in the prosthesis is proposed. The polyethylene insert was divided in two parts: top and bottom. On the upper insert two excavations are made, one in the medial side of the tibial plate and the other in the lateral side. Two sensorized metal bars are placed on the hole as shown in Figure 1. The excavations are made exactly under the contacts point of condyles for directly transmit the forces on the sensors. In the bottom insert the conditioning electronic is placed.

The insert was processed with a numeric control milling machine. The excavations have dimensions 20 mm x 20 mm. The metal bars are made by inox steel AISI 430 with thickness of 0.8 mm with the same dimensions of the holes. The two metal bars are sensorized by strain gauges (with resistance of 120 Ω, Gauge factor 1.88, dimension 5 mm x 5 mm commercialized by HBM), and placed under the bars as shown in Figure 1. With the aim of transferring directly the forces on metal bars, the femoral condyles are placed directly over the metal bars. To ensure the biocompatibility of polyethylene insert, on the superior face of the insert 2 mm thick film of polyethylene was placed for covering the metal part of the fabricated sensors. When a force is applied through the femoral condyles, the metal bars are bent. Young's modulus of inox steel AISI 430 is 196000 N/mm² and the Young's modulus of

polyethylene is 2600 N/mm². Increasing the Young's modulus of bent material, the material's hysteresis has been reduced.

Another advantage by this configuration is to increase the rigidity of the insert. The deformation of metal bars is very small, so that the mechanical properties of the insert are very similar to the not sensorized insert.

The resistances of strain gauges are measured by inserting the strain gauges in two Wheatstone bridges. The measured differential voltage of each bridge was amplified and sampled by a digital multimeter connected by GPIB bus with a PC. The differential voltage is proportional to the force applied by the femoral condyles.

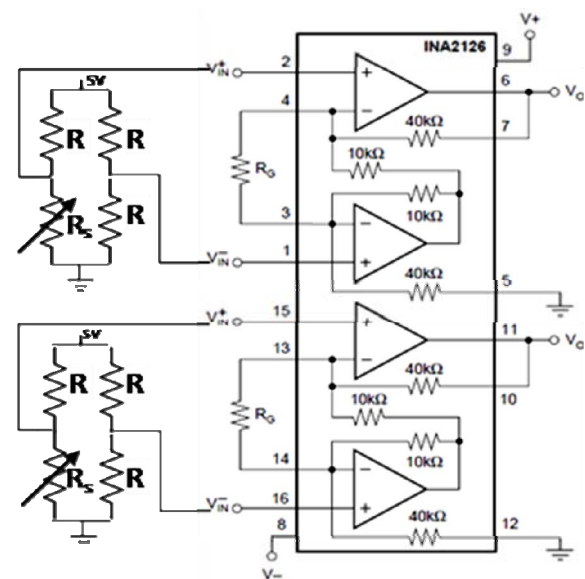

Figure 2: Conditioning electronics of integrated sensors.

In Figure 2, the conditioning electronics of integrated sensors are shown. The systems are composed by two Wheatstone bridges. The R_s variable resistors are the strain gauge applied to the metal bars, while the R resistors are the fixed resistors of Wheatstone bridge. R_g resistors are used to fix the gain of instrumentation amplifiers. The differential voltages are measured and amplified by a micro power dual instrumentation amplifier, INA2126, produced by Burr-Brown. The INA2126 has two precision instrumentation amplifiers for accurate, low noise differential signal acquisition. The two-op-amp design provides excellent performance with very low quiescent current. The output voltages are measured by two digital multimeters (Fluke HP8810).

3 EXPERIMENTAL SETUP

The sensorized polyethylene insert is tested and characterized by an Instron 8501 force machine. The polyethylene insert was placed on the fixed part of the Instron machine and the femoral component was placed on the mobile component and the forces were applied. The experimental setup is shown in Figure 3.

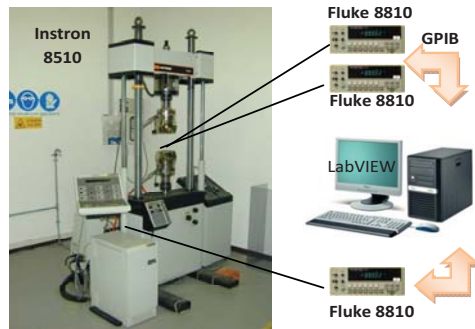

Figure 3: Experimental setup with Instron machine and measurement system.

The force control is made by a load cell integrated and controlled by the Instron machine. The Instron machine has an output voltage proportional to the applied force. This voltage is measured by the digital multimeter (Fluke HP8810). It lets you know the profile of force value applied to the polyethylene insert.

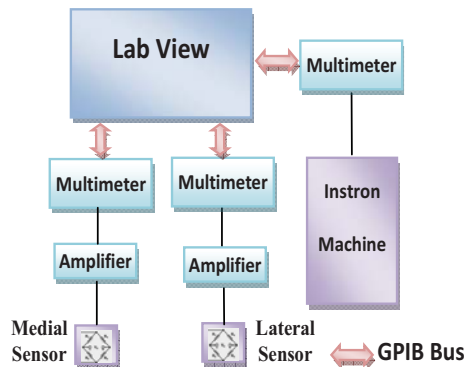

Figure 4: Block diagram of the experimental setup.

In Figure 4, the block diagram of experimental setup adopted to test the realized sensors was represented. The two strain gauges are placed in a Wheatstone bridge, the differential voltages are measured by two instrumentation amplifiers and the measured voltages are sampled by two digital multimeters (Fluke HP8810) connected by GPIB bus to PC. The Instron machine has an output voltage proportional to the generated force. The voltage is sampled by a

digital multimeter (Fluke 8810), connected by GPIB bus to PC. Dedicated software LabVIEW is realized, it allows to acquire the data and store the differential voltage (Medial and Lateral Sensors) and the voltage proportional to the force applied in single file. The Instron machine is programmed to apply to the polyethylene insert a very slow variation of load forces. The applied forces start from 300 N to 1000 N. This force profile is used for the sensor characterization. Using the experimental setup showed in Figure 4 the Medial and Lateral Sensor are characterized. The Instron machine is programmed to generate the force profile previously described. The measurement information are stored in a single file and digitally elaborated.

The data obtained are showed in Figure 5. For clarity of content only the characterization of Medial Sensor was reported. The results of Lateral Sensor are the same.

The output voltage from instrumentation amplifiers is proportional to the applied force, and the relationship between force and voltage is linear.

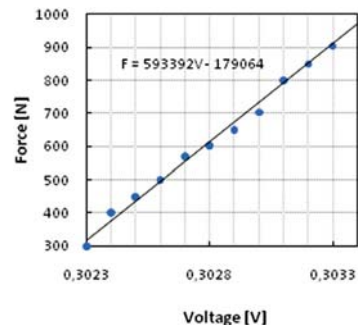

Figure 5: Medial sensor characterization.

The measured voltage was interpolated with a linear straight and his equation (1) that correlates the voltage with applied force is:

$$F = 593392 \cdot V - 179064 \quad (1)$$

Where F is the force applied in newtons (N) and V is the measured voltage in volts (V).

4 CONCLUSIONS

In this paper the authors propose a different sensor technology for force measurement in a total prosthesis of human knee and it is fully contained in the polyethylene insert. The proposed sensors consist in two metal bars positioned under the femoral condyle. The metal bars are made on inox steel AISI 430 because it has a high Young's

modulus. That allows reducing the material's hysteresis. The metal bars are sensorized by two strain gauges. The sensor characterization was done and the obtained data show a linear relationship between the applied forces and the measured voltages.

These sensors can be integrated in an autonomous system that does not require internal power sources, such as batteries. The autonomous system can integrate an energy harvesting module that extracts energy from magnetic field.

The forces transmitted across the knee joint during normal human activities such as walking, running or climbing can be directly measured. Furthermore, the device can be used to improve design, refine surgical instrumentation, guide post-operative physical therapy and detect human activities that can overload the system.

The sensorized total knee prosthesis will be tested by a robotic mannequin for dynamical characterization. The robotic mannequin can simulate the human walking. During the test the polyethylene insert will be subjected to dynamic forces and it will be possible to make a pseudo in-vivo dynamic characterization of the sensors.

REFERENCES

- Gattiker, F., Umbrecht, F., Neuenschwander, J., Sennhauser, U., Hierold, C., 2008. Novel ultrasound read-out for a wireless implantable passive strain sensor (WIPSS), *Sensors and Actuators A* 145–146 291–298.
- Westerhoff, P., Graichen, F., Bender, A., Rohlmann, A., Bergmann, G., 2009. An instrumented implant for in vivo measurement of contact forces and contact moments in the shoulder joint, *Medical Engineering & Physics* 31 207–213.
- Heinlein, B., Graichen, F., Bender, A., Rohlmann, A., Bergmann, G., 2007. Design, calibration and pre-clinical testing of an instrumented tibial tray, *Journal of Biomechanics* 40 S4–S10.
- Crescini, D., Sardini, E., Serpelloni, M., 2009. An Autonomous Sensor for Force Measurements in Human Knee Implants, *Proceedings of the Eurosensors XXIII conference Procedia Chemistry* 1(1) 718-721.